

Vibrabsorber **VT**



Range designed for suspension of suspended acoustic ceilings and machinery operating at more than 450 r.p.m. These isolators are made of piano tail spring quality with a high mechanical performance. They incorporate rubber bush conceived to avoid the "acoustic bridges" and the contact of a non aligned screw. The metallic structure is very robust and it is supplied with an anti-corrosive zinc-plated coat.



Vibrabsorber VT

DRAWINGS

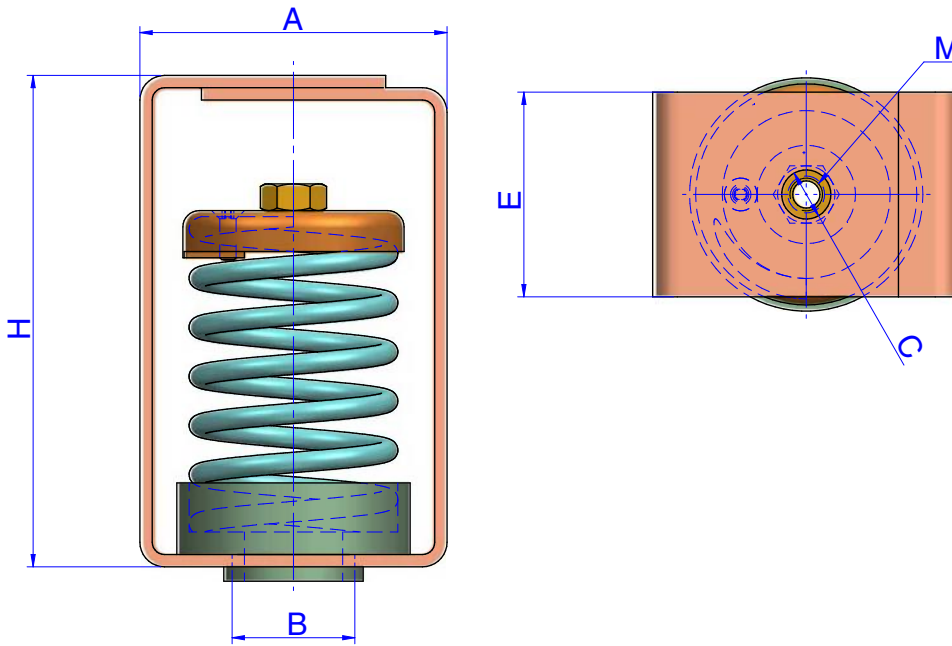

DIMENSIONS

Type	A (mm.)	Spring color	B (mm.)	C (mm.)	E (mm.)	H (mm.)	M	Code
VT 25	75	BLACK	30	12	50	120	M-8	20201
VT 50	75	BLUE	30	12	50	120	M-8	20202
VT 75	75	GREY	30	12	50	120	M-8	20203
VT 100	75	BEIGE	30	12	50	120	M-8	20204
VT 125	75	WHITE	30	12	50	120	M-8	20211
VT 150	120	BLUE	30	16	80	160	M-12	20205
VT 200	120	WHITE	30	16	80	160	M-12	20210
VT 250	120	BLACK	30	16	80	160	M-12	20206
VT 350	120	CREAM	30	16	80	160	M-12	20207
VT 500	140	LIGHT GREY	30	16	100	180	M-14	20208
VT 750	140	GREEN	30	16	100	180	M-14	20209

Vibrabsorber VT

ELASTICAL PROPERTIES

